

Roll Gap Control/Web Thickness Measurements

GOAL

Controlling the gap between two rollers used to press and process web material (rubber, paper, dough, etc.).

Maintaining a precise material thickness.

Avoiding web damage or web jams from excessive roller pressure.

Minimizing roller wear and cost.

Making measurements in the presence of environmental contaminants, such as paper dust and dirt.

SOLUTION

KD-2306
KDM-8206

Two Kaman sensors are mounted on bearing blocks, one on each end of the top roller (see Figure 1). A conductive target is mounted on the opposite bearing block. The sensor measures the distance to the target as the web is running.

Kaman's system provides a DC analog signal — or an optional digital interface — directly proportional to the roller gap. The data indicates roll gap uniformity across the web. This information can be used for initial set-up and for process control through a feedback network.

Result: Improved web quality, lower maintenance costs, and reduced process costs.

THE KAMAN ADVANTAGE

Good reasons to use the Kaman KD-2306 and KDM-8206 measuring system:

Non-contact. Using eddy current technology, the sensor can measure position without ever touching the target. The result is an extremely reliable system with no moving parts.

On-line. The sensors measure the roller gap as the web is being processed. Pre-programmed limits (rollers too close or too far apart, wad detection, or other conditions) warn of an out-of-tolerance situation, providing complete on-line control.

Rugged. Kaman's system components — the sensors and a NEMA-12 box used to house the signal conditioning electronics — are unaffected by environmental contaminants or by the water used to wash the rollers.

Accurate. The system passively compensates for the temperature shifts of the process environment.

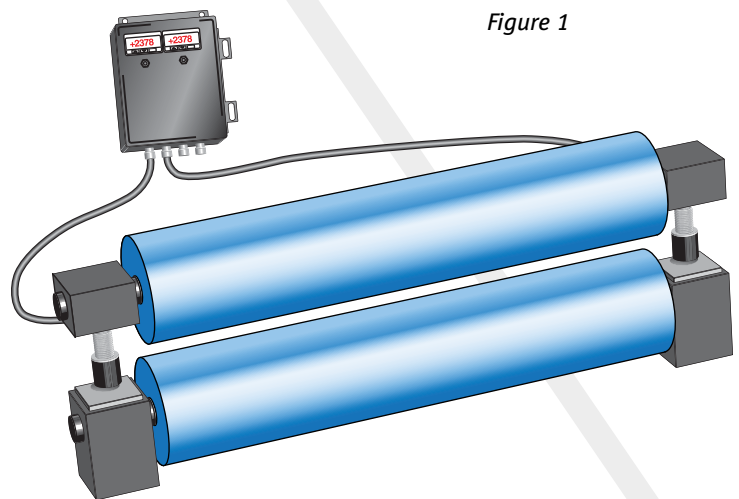

Figure 1

Every application is unique.
Contact Kaman for application engineering assistance.

800-552-6267 | kamansensors.com | measuring@kaman.com

KAMAN
PRECISION PRODUCTS